



Vascular Technology

Instructions for Use

VTI 8 and 20 MHz Doppler Systems

REF. 108910, 108910-AC, 108400-AC, and 108400

Table of Contents	
Technical Description	3
Intended Use	4
Warnings.....	4
Cautions:.....	5
Operation.....	7
Environment	7
Power.....	7
Physical – REF 108400-AC and 108910-AC	8
Physical – REF 108400 and 108910	8
Explanation of Symbols.....	8
Transceiver Description	10
System Block Diagram	13
Setup.....	14
Battery Installation	14
Power Supply Installation	14
Transceiver Placement.....	15
Immunity Test.....	16
Performance Criteria	25
Essential Performance	25
Doppler Probe Selection	26
Doppler Probe Connection	26
Preparation for Use	27
Flow Determination.....	27
Trouble Shooting Guide.....	30
Service	33
Maintenance and Cleaning	33
Battery Replacement	34
Accessories & Parts.....	34
Limited Warranty.....	36

Technical Description

Both the VTI 8 and 20 MHz Doppler Transceivers are manufactured by Vascular Technology Inc. and are available operating from batteries or operating from batteries and an external power supply. The REF 108910-AC and 108400-AC Doppler Transceivers are externally DC powered pulsed Doppler ultrasound systems designed for the evaluation of blood velocity in vessels. The REF 108910-AC and 108400-AC Doppler Transceivers can also be powered by eight standard AA (LR6) alkaline batteries. The REF 108910 and 108400 Doppler Transceivers can only be powered by eight standard AA (LR6) alkaline batteries and are also designed for the evaluation of blood velocity in vessels.

The VTI 8 and 20 MHz Doppler Systems allow the user to interrogate vessels. A Doppler transducer (probe), which plugs into the transceiver unit, emits a pulsed ultrasonic signal. A varying audible signal is produced when the probe is placed upon a vessel within which there is flow. The frequency (i.e., pitch) of the signal is proportional to the blood velocity within the vessel. Distinctive tonal patterns are produced which are indicative of the flow pattern in terms of velocity vs. time. The volume of the tone may be adjusted by means of a control located on the transceiver. A transmitter in the transceiver periodically drives the ultrasonic transmitting crystal located at the tip of the probe. The ultrasonic waves generated by the crystal travel through the tissue just under the probe tip in a fairly narrow beam. They are then reflected back towards the probe whenever they encounter a boundary between tissues of different densities. During the intervals when the unit is not transmitting, the probe passes any reflected signals that it receives to a receiving circuit. This circuit amplifies the returning echoes, compares their frequency to that

of the transmitted signal and converts any frequency differences into an audible tone.

Intended Use

The VTI 8 and 20 MHz Doppler Transceivers are intended for the intraoperative and transcutaneous evaluation of blood flow. Indications for Use form filed with the FDA for the VTI Doppler Probes lists the clinical applications as Intraoperative (microvascular and vascular), Intraoperative Neurological, Transesophageal, Transrectal, Laparoscopic and Peripheral Vascular.

European Union Notice:

The Doppler probes are intended for general use and each probe is intended to be used in multiple surgical specialties. The Doppler probes are not intended specifically for use in direct contact with the central nervous system (brain, meninges and spinal cord). The Doppler probes are not intended specifically to control, diagnose, monitor or correct a defect of the heart or of the central circulatory system through direct contact with these parts of the body. The Doppler probes are not intended to be dedicated disposable cardiovascular surgical instruments. The user must follow all Warnings, Cautions and Contraindications associated with this device.

All VTI Doppler probes are designed to be safe and effective when used properly. To reduce the risk of hazards to a level as low as reasonably achievable, and to limit exposure to ultrasound, turn the unit off when not in use.

Warnings

WARNING: *This label alerts the operator to possible bodily injury if procedures are not followed exactly.*

WARNING: Never sterilize the Transceiver with autoclave, ultraviolet, gamma radiation, gas, steam, or heat sterilization

techniques. Severe damage and personal injury could result.

WARNING: There are no user serviceable components inside this device other than the batteries. Disassembly of the internal components of this unit may result in circuit damage. All servicing should be referred to the factory. Do not modify this device.

WARNING: Not for use in OXYGEN ENRICHED atmospheres

WARNING: Remove batteries during prolonged storage. Do not install backwards, charge, put in fire, or mix with other battery types. May explode or leak causing injury. Replace all batteries at the same time.

WARNING: Equipment not suitable for use in the presence of a FLAMMABLE ANESTHETIC MIXTURE WITH AIR OR WITH OXYGEN OR NITROUS OXIDE.

WARNING: The VTI Doppler system should not be used adjacent to or stacked with other equipment. If adjacent or stacked use is necessary, the VTI Doppler system should be observed to verify normal operation in the configuration in which it will be used.

Cautions:

CAUTION: *This label alerts the operator to possible equipment or software damage if procedures are not followed correctly.*

CAUTION: This Doppler device is not intended for fetal use.

CAUTION: Prior to use, inspect probe for damage, such as

cracks that could allow for the ingress of fluids into the probe, and sharp edges.

CAUTION: Use only AA (LR6) alkaline batteries.

CAUTION: Use transceiver only with compatible power supply.

CAUTION: Because the VTI 20 MHz Doppler Transceiver needs to be sensitive to very weak signals from blood flow, by design it may be susceptible to picking up interference through the coaxial cable that connects the Doppler probe to the transceiver.

CAUTION: Use transceiver only with compatible Doppler probes.

CAUTION: Do not re-use single-use disposable probes. Reuse may lead to cross contamination and mechanical damage.

CAUTION: The Doppler probe is delicate. Do not drop or strike against hard surfaces. Avoid excessive mechanical pressure on the probe or excessive tension on the probe cable. Check to insure connectors are not loose.

CAUTION: To avoid biological hazards, properly dispose of probe according to local regulations.

CAUTION: Properly dispose of batteries according to local regulations. Transceiver and power supply may be returned to manufacturer for proper disposal.

CAUTION: The transceiver should not be used in the presence of any high frequency equipment, including high

frequency surgical generators.

Operation	
Transmission Frequency	8 or 20 MHz
Transmission Characteristic	Pulsed transmission, continuous reception

Environment	
Ambient Operating Temperature Range	+15° to +40°C.
Ambient Operating Humidity Range	30% to +75% RH
Ambient Shipping Humidity Range	30% to +75% RH
Ambient Shipping Temperature Range	-15° to +70° C.
Ambient Storage Temperature Range	-15° to +40° C.
Ambient Storage Humidity Range	30% to +75% RH
IPX 0 (Transceiver)	No special protection
IPX 7 (Probe)	Protected against water immersion - Immersion for 30 minutes at a depth of 1 meter.
Surface Temperature - probe	Less than 41°C

Power	
REF 108910-AC and 108400-AC Doppler Transceiver	8 AA (LR6) alkaline batteries and External Power Source, A/C to D/C Power Supply

REF 108910 and 108400 Doppler Transceiver	8 AA (LR6) alkaline batteries
Power Requirements	12 VDC

Physical – REF 108400-AC and 108910-AC

Dimensions	6.5 in. D X 10 in. W X 4 in. H. (165 mm X 254 mm X 101 mm), nom
Weight	2.6 lb, (1.18 kg), nom.

Physical – REF 108400 and 108910

Dimensions	4.25" D X 3.75" W X 5.25" H (105mm X 95mm X 135mm), nom
Weight	1.4 lb, (0.6 kg) nom

Explanation of Symbols	
Sterilized by Ethylene Oxide	IQ
Do Not Re-use	D
Follow Instructions for Use	
Date Manufactured	N

Use By	H
Type CF Applied Part	♥
Catalog Number	h
Lot	g
Serial Number	f
Keep Dry	p
Direct Current	- - -
Protection From Ingress of Water	IPX
RF transmitter	Ⓜ
Authorized representative in the European Community	P
Limit of temperatures	l

Transceiver Description

REF 108400-AC and 108910-AC



Fig. 4-1 REF 108910-AC and 108400-AC Doppler Transceiver
(20 MHz System is depicted)

1. Power Switch: A push-button control that when depressed turns the unit ON. Power ON is indicated by illumination of one of the four green Volume Setting LEDs. When the push-button is depressed a second time the unit is turned OFF.
2. Volume Indicator: A series of green LEDs that indicates the volume of the audible Doppler signal.

3. Volume Increase Switch: A push-button switch that when depressed and held will increase the volume of the audible Doppler signal.
4. Volume Decrease Switch: A push-button switch that when depressed and held will decrease the volume of the audible Doppler signal.
5. Low Battery Indicator: A yellow LED which, when illuminated, indicates that the batteries are nearing the end of their useful life. The system will automatically shut OFF when the battery voltage is too low to maintain proper operation of the unit.

Transceiver Description
REF 108400 and 108910

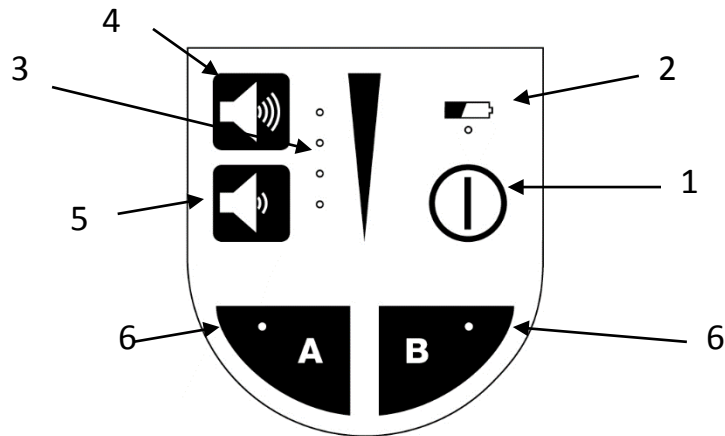

Fig. 4-2 REF 108910 and 108400 Doppler Transceiver (8 MHz System is depicted)

1. Power Switch: A push-button control that when depressed turns the unit ON. Power ON is indicated by illumination of any of the green Volume Setting LED's. When the push-button is depressed a second time the unit is turned OFF.
2. Battery Low Indicator: A yellow LED which, when illuminated, indicates that the batteries are nearing the end of their useful life. The system will automatically shut OFF when the battery voltage is too low to maintain proper operation of the unit.
3. Volume Indicator: A series of green LED's that indicates the volume of the audible Doppler signal.
4. Volume Increase Switch: A push-button switch that when depressed and held will increase the volume of the audible

Doppler signal

5. Volume Decrease Switch: A push-button switch that when depressed and held will decrease the volume of the audible Doppler signal.

6. Channel Select Switch: (REF 10910 only) A push-button switch that when depressed changes the active channel between A and B. An amber LED indicates the active channel.

System Block Diagram

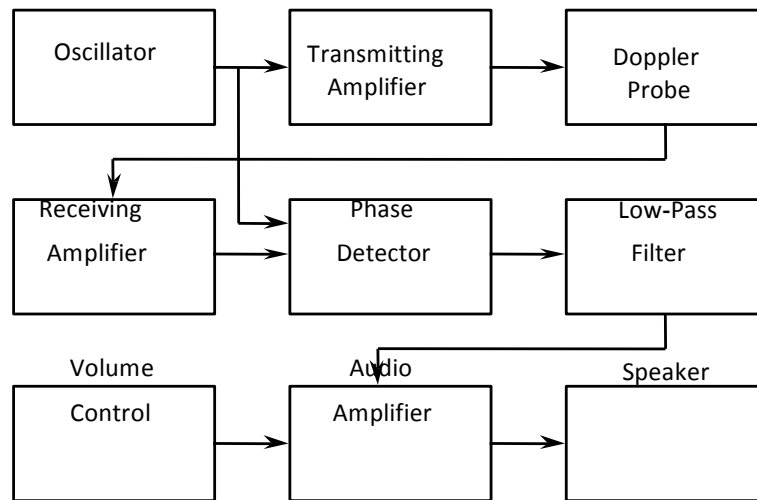

CAUTION: Prior to use, inspect probe for damage, such as cracks that could allow for the ingress of fluids into the probe, and sharp edges.

Carefully unpack your VTI Doppler Transceiver. Inspect the transceiver for damage. If the transceiver is missing or any damage is found, contact the factory for further instructions.

Setup

Battery Installation

CAUTION: Use only AA (LR6) alkaline batteries.

Install the batteries per the instructions in the Service Information section of this manual.

Power Supply Installation

CAUTION: On models that use a power supply, use only with compatible power supply.

On models that use a power supply, connect power supply to wall grounded hospital grade outlet using hospital grade cord set. Connect power connector to D/C outlet on unit.

On models that use a power supply, patient isolation from the mains is accomplished in the following ways: First, an external medical grade power supply is used to provide D.C. operating voltage for the Doppler unit. Both D.C. power output lines from the power supply are isolated from the mains in the D.C. power supply. There is no connection between the "green" safety

ground and the Doppler unit. Additionally, Doppler probes that make patient contact are further isolated by use of an RF isolation transformer that isolates both signal and ground leads between the Doppler unit and the Doppler probe. The transducer coaxial shield is connected to the Doppler unit chassis ground through two safety capacitors. Both the capacitors and the isolation transformer have a 4000VAC dielectric withstand voltage. The final isolation mechanism is the cable insulation and potting of the probe providing an additional insulation layer between the isolated electrical signals and the patient.

Transceiver Placement

CAUTION: Because the VTI Doppler Transceiver needs to be sensitive to very weak signals from blood flow, by design it may be susceptible to picking up interference through the coaxial cable that connects the Doppler probe to the transceiver.

The VTI Doppler Transceiver needs special precautions regarding EMC and needs to be installed and put into service according to the EMC information located in this Instructions for Use manual.

Portable and mobile RF communications equipment can affect the VTI Doppler Transceiver.

WARNING: The VTI Doppler Transceiver should not be used adjacent to or stacked with other equipment. If adjacent or stacked use is necessary, the VTI Doppler system should be observed to verify normal operation in the configuration in which it will be used.

Place VTI Doppler Transceiver on a suitable stand, cart or table outside the sterile field, just behind the physician who will be using the Doppler system. The VTI Doppler Transceiver should not be used in the presence of any high frequency equipment, including high frequency surgical generators. The transceiver has a rating of IPX-0. Keep the transceiver away from all open liquids.

Immunity Test

Table 1 Guidance and manufacturer’s declaration – electromagnetic emissions		
The VTI Doppler systems are intended for use in the electromagnetic environment specified below. The user of the VTI Doppler system should assure that it is used in such an environment.		
Emissions Test	Compliance	Electromagnetic Environment -- guidance
RF Emissions, CISPR 11	Group 1	The VTI Doppler system uses RF energy only for its internal function. Therefore, its RF emissions are very low and are not likely to cause any interference in nearby electronic equipment.
RF Emissions CISPR 11	Class A	The VTI Doppler systems meet the conducted and radiated performance requirements for non-life supporting equipment and also meet the harmonic emissions, voltage dips and variations and voltage fluctuation
Power Harmonic emissions	Not Applicable (see Note)	

Voltage fluctuations/flicker emissions	Not Applicable (see Note)	<p>(flicker) requirements for non-life supporting equipment pursuant to IEC 60601-1-2:2007 and CISPR 11, A1 & A2, and IEC 61000-3-3.</p> <p>The VTI Doppler systems are suitable for use in all establishments other than domestic, and may be used in domestic establishments and those directly connected to the public low-voltage power supply network that supplies buildings used for domestic purposes, provided the following warning is heeded:</p> <p>Warning: The VTI Doppler systems are intended for use by healthcare professionals only. The VTI Doppler systems may cause radio interference or may disrupt the operation of nearby equipment. It may be necessary to take mitigation measures, such as re-orienting or relocating the VTI Doppler system or shielding the location.</p>
NOTE: Outside the scope of the standard.		

Table 2 Guidance and manufacturer's declaration – electromagnetic Immunity

The VTI Doppler systems are intended for use in the electromagnetic environment specified below. The customer or the user of the VTI Doppler system should assure that it is used in such an environment.

Immunity test	IEC 60601 test level	Compliance level	Electromagnetic environment -- guidance
Electrostatic discharge (ESD) IEC 61000-4-2	+/- 6 kV contact +/- 8 kV air	+/- 2, +/- 4 and +/- 6 kV Contact Discharge. +/- 2, +/- 4, and +/- 8 kV Air Discharge	Floors should be wood, concrete or ceramic tile. If floors are covered with synthetic material, the relative humidity should be at least 30%.
Electrical fast transient/burst IEC 61000-4-4	+/- 2 kV AC Mains +/- 1 kV I/O Ports	+/- 2 kV AC Mains +/- 2 kV I/O Ports	Mains power quality should be that of a typical commercial or hospital environment.

Surge IEC 61000-4-5	+/- 1 kV line(s) to line(s) +/- 2 kV line(s) to earth	+/- 1 kV line to line (DM) +/- 2 kV line(s) to earth (CM)	Mains power quality should be that of a typical commercial or hospital environment.
Voltage dips, short interruptions and voltage variations on power supply input lines. IEC 61000-4-11	<5% U_T (>95 % dip in U_T) for 0,5 cycle.) 40 % U_T (60 % dip in U_T) for 5 cycles 70 % U_T (30 % dip in U_T) for 25 cycles <5 % U_T (>95 % dip in U_T) for	10 ms >95 % dip (0.5 period) 100 ms 60 % dip (5 periods) 500 ms 30 % dip (25 periods) 5 seconds > 95 % dip/interruptions (300 periods)	Mains power quality should be that of a typical commercial or hospital environment. If the user of the VTI Doppler system requires continued operation during power mains interruptions, it is recommended that the VTI Doppler system be powered from an uninterruptible power supply or the built-in battery.

	5 s		
Power frequency (50/60 Hz) magnetic field IEC 61000-4-8	3 A/m	3 A/m 50 Hz & 60 Hz three orthogonal orientations	Power frequency magnetic fields should be at levels characteristic of a typical location in a typical commercial or hospital environment.
NOTE: U_T is the a.c. mains voltage prior to application of the test level.			

Table 3 Guidance and manufacturer’s declaration – electromagnetic immunity

The VTI Doppler system are intended for use in the electromagnetic environment specified below. The customer or the user of the VTI Doppler system should assure that it is used in such an environment.

IMMUNITY TEST	IEC 60601 TEST LEVEL	COMPLIANCE LEVEL	ELECTROMAGNETIC ENVIRONMENT -- GUIDANCE
<p>Conducted RF IEC 61000-4-6</p>	<p>3 Vrms 150 kHz to 80 MHz</p>	<p>$[V_1]V = 3$ Vrms</p>	<p>Portable and mobile RF communications equipment should be used no closer to any part of the Doppler system, including cables, than the recommended separation distance calculated from the equation applicable to the frequency of the transmitter.</p> <p>Recommended separation distance:</p> $d = \left[\frac{3.5}{V_1} \right] \sqrt{P} = 1.2 \sqrt{P}$

<p>Radiated RF</p> <p>IEC 61000-4-3</p>	<p>3 V/m</p> <p>80 MHz to 2,5 GHz</p>	<p>$E_1 = 3 \text{ V/m}$</p>	$d = \left[\frac{3.5}{E_1} \right] \sqrt{P} = 1.2 \sqrt{P}$ <p>80 MHz to 800 MHz</p> $d = \left[\frac{7}{E_1} \right] \sqrt{P} = 2.3 \sqrt{P}$ <p>800 MHz to 2.5 GHz</p> <p>Where P is the maximum output power rating of the transmitter in watts (W) according to the transmitter manufacturer and d is the recommended separation distance in meters (m)</p> <p>Field strengths from fixed RF transmitters, as determined by an electromagnetic site survey,^a should be less than the compliance level in each frequency range.^b</p> <p>Interference may occur in the vicinity of equipment marked with the</p>
---	---------------------------------------	---	--

			<p>following symbol:</p> 
<p>NOTE 1: At 80 MHz and 800 MHz, the higher frequency range applies.</p> <p>NOTE 2: These guidelines may not apply in all situations. Electromagnetic propagation is affected by absorption and reflection from structures, objects and people.</p>			
<p>^a Field strengths from fixed transmitters, such as base stations for radio (cellular/cordless) telephones and land mobile radios, amateur radio, AM and FM radio broadcast and TV broadcast cannot be predicted theoretically with accuracy. To assess the electromagnetic environment due to fixed RF transmitters, an electromagnetic site survey should be considered. If the measured field strength in the location in which the Doppler system is used exceeds the applicable RF compliance level above, the Doppler system should be observed to verify normal operation. If abnormal performance is observed, additional measures may be necessary, such as re-orienting or relocating the Doppler system.</p> <p>^b Over the frequency range 150 kHz to 80 MHz, field strengths should be less than 3 V/m.</p>			

Table 4 Recommended separation distances between portable/mobile RF communications equipment and the VTI Doppler systems.

The Doppler systems are intended for use in an electromagnetic environment in which radiated RF disturbances are controlled. The customer or the user of the VTI Doppler system can help prevent electromagnetic interference by maintaining a minimum distance between portable and mobile RF communications equipment (transmitters) and the Doppler system as recommended below, according to the maximum output power of the communications equipment.

Rated maximum output power of transmitter w	Separation distance according to frequency and power of transmitter (m)		
	150 kHz to 80 MHz	80 MHz to 800 MHz	800 MHz to 2,5 GHz
	$d = 1.2\sqrt{P}$	$d = 1.2\sqrt{P}$	$d = 2.3\sqrt{P}$
0,01	0,12	0,12	0,23
0,1	0,38	0,38	0,74
1	1,2	1,2	2,3
10	3,8	3,8	7,4
100	12	12	23

For transmitters rated at a maximum output power not listed above, the recommended separation distance d in meters (m) can be estimated using the equation applicable to the frequency of the transmitter, where P is the maximum output power rating of the transmitter power in watts (W) according to the transmitter manufacturer.

NOTE 1: At 80 MHz and 800 MHz, the separation distance for the higher frequency applies.

NOTE 2: These guidelines may not apply in all situations. Electromagnetic propagation is affected by absorption and reflection from structures, objects and people.

Performance Criteria

Failures include any time the unit does not produce an audible signal when detectable flow is present. In addition to component malfunction, failures also include units that produce a false audible that is indistinguishable from a signal produced by flow. Non-intentional audible signal tones are allowed to be produced by the unit, so long as they cannot be easily mistaken for flow.

Essential Performance

The VTI Doppler system is not intended to be used as the sole indicator of blood flow detection. Other clinical means should be utilized to check for failure or degradation of the VTI Doppler Transceiver.

The equipment or system may exhibit degradation of performance (e.g. Deviation from specifications) that does not affect essential performance or safety. If the Doppler probe cable is in close proximity to electrically active conductors, such as an electro-surgery cables or an electronic

equipment chassis, signals from the cables or chassis may be picked up by the VTI 20 MHz Doppler Transceiver and produce audible signals that will be heard along with the desired Doppler audio. This interference is easily distinguished from blood flow and is remedied by moving the transducer cable away from the source of the interference. Always recheck the VTI 20 MHz Doppler Transceiver for proper function after this interference has occurred.

WARNING: Equipment not suitable for use in the presence of a FLAMMABLE ANESTHETIC MIXTURE WITH AIR OR WITH OXYGEN OR NITROUS OXIDE.

WARNING: Not for use in OXYGEN ENRICHED atmospheres.

Doppler Probe Selection

CAUTION: Use transceiver only with compatible Doppler probes.

VTI Doppler Transceivers are designed to function only with Doppler probes that are compatible. Patient contact areas of the probe are rated at IPX-7. Keep connectors away from all liquids. Acoustical output tables and information required by IEC60601-2-37 can be found in the inserts provided with the Doppler probes.

Doppler Probe Connection

Using sterile technique when appropriate, remove the sterile Doppler probe from its packaging. Hand-off the probe's connector to someone outside the sterile field. Attach the probe's connector to the coaxial receptacle on the transceiver

front panel.

WARNING: Never sterilize the Transceiver with autoclave, ultraviolet, gamma radiation, gas, steam, or heat sterilization techniques. Severe damage and personal injury could result.

Preparation for Use

Plug the power cord into a hospital grade electrical outlet or allow the unit to be powered from the internal battery source. Turn the transceiver on by depressing the Power Switch. The initial volume level will be maintained from the previous use.

Adjust the volume by depressing and holding the Volume Increase or Decrease push-button to an intermediate level. Some “white” noise (white noise sounds similar to a radio that is tuned between stations) may be heard from the transceiver speaker. To verify that the system is operational, gently draw the tip of the Doppler probe, using sterile technique, along any convenient sterile surface. This will produce a fairly loud rasping noise, confirming that the system is operational.

CAUTION: Prior to use, inspect probe for damage, such as cracks that could allow for the ingress of fluids into the probe, and sharp edges

CAUTION: The Doppler probe is delicate. Do not drop or strike against hard surfaces. Avoid excessive mechanical pressure on the probe or excessive tension on the probe cable. Check to insure connectors are not loose.

Flow Determination

Place the tip of the probe directly on the vessel or other site to

be evaluated, orienting the probe as shown in figure 6-1. Adjust the angle between the probe and the vessel until the maximum audible signal is obtained. Adjust the volume control on the transceiver to the desired level. \If any flow is detected, the pitch of the resultant audible signal will correspond to its velocity, with higher pitches indicating higher velocities. The probe may be moved to various sites as required.

When the entire procedure is finished, turn the transceiver power OFF by depressing the Power switch. Clean the transceiver, if necessary, as described in the Service Information section. Properly dispose of probe according to local regulations.

CAUTION: To avoid biological hazards, properly dispose of probe according to local regulations.

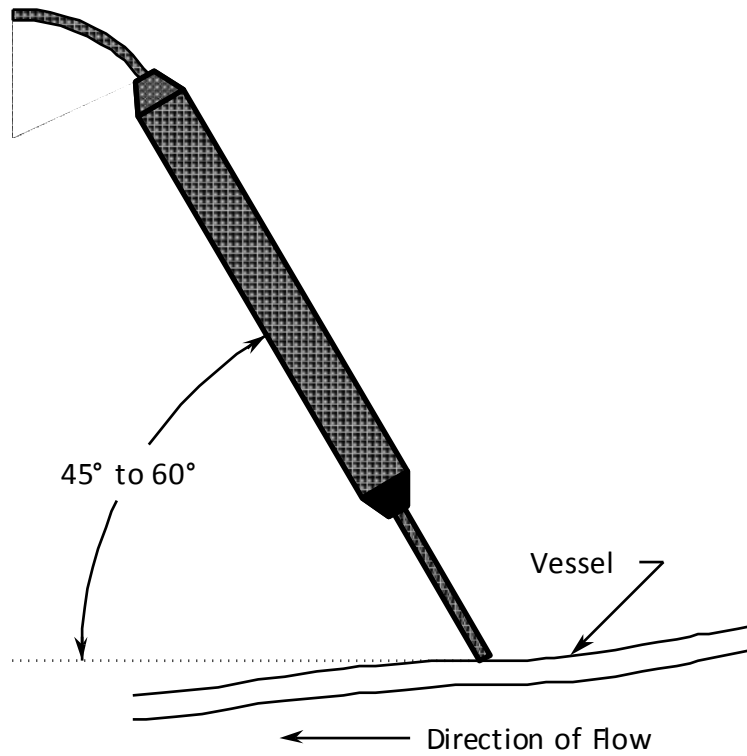

Fig. 6-1 Representative Doppler Probe Orientation – Refer to Instructions for Use supplied with individual probes for specific details.

Trouble Shooting Guide

Symptoms	Possible Problems & Solutions
Weak sound output, even at maximum volume setting.	The flow that is being heard is somewhat deeper than this unit is designed to detect.
	Weak batteries (yellow lamp). Replace.
	Doppler probe may be defective. Return to the factory.
	Transceiver may be defective. Return to the factory for repair.

<p>“White” noise occurs at maximum volume setting and drawing the probe tip over a surface results in a rasping noise, but probe does not detect flow.</p>	<p>Doppler probe is correctly evaluating a zero velocity condition. No problem.</p>
	<p>.....</p> <p>Doppler probe is not positioned correctly. Review Operation section.</p>
	<p>.....</p> <p>Doppler probe may be defective. Return to the factory for repair.</p>
	<p>.....</p> <p>Transceiver may be defective. Return to the factory for repair.</p>
	<p>.....</p> <p>Doppler probe not connected. Connect.</p>
	<p>.....</p> <p>Doppler probe may be defective. Return to the factory for repair.</p> <p>.....</p> <p>Transceiver may be defective. Return to the factory for repair.</p>

<p>“White” noise occurs at maximum volume setting, but drawing the probe tip over a surface does not result in a rasping noise.</p>	<p>Doppler probe not connected. Connect.</p> <p>.....</p> <p>Doppler probe may be defective. Return to the factory for repair.</p> <p>.....</p> <p>Transceiver may be defective. Return to the factory for repair.</p>
<p>No sound whatsoever, at any volume control setting; low battery indicator not illuminated.</p>	<p>Power Supply not connected. Connect.</p> <p>.....</p> <p>Power Supply may be defective. Return to the factory for repair.</p> <p>.....</p> <p>Transceiver may be defective. Return to the factory for repair.</p>

If the problem cannot be corrected after making the above checks and adjustments, call Vascular Technology for additional help or return authorization at (603) 594-9700 between the hours of 9:00 A.M. and 5:00 P.M. Eastern Time, Monday through Friday.

Service

If you have any problems operating your instrument, read the instructions again, paying particular attention to the sequential order of steps; or consult the Troubleshooting section

WARNING: There are no user serviceable components inside this device other than the batteries. Disassembly of the internal components of this unit may result in circuit damage. All servicing should be referred to the factory.

Maintenance and Cleaning

The transceiver requires little maintenance. Keep it clean and free of dust. The exterior may be cleaned using the following steps:

1. After every use, check the transceiver for any sign of damage or wear.
2. Wipe the Transceiver with a dry or water-moistened soft cloth.
3. Wipe the Transceiver with Isopropyl alcohol (70%) moistened soft cloth or wipe. Do not pour 70% isopropyl alcohol directly on the Transceiver. Always use a moistened soft cloth or wipe. Allow to air dry before use.
4. Check the Transceiver for any residual organic material. If any is present, remove it and disinfect the Transceiver again.

The transceiver should not contact mucus membranes, blood, or compromised tissue, and is not used in sterile

fields.

WARNING: Never sterilize the Transceiver with autoclave, ultraviolet, gamma radiation, gas, steam, or heat sterilization techniques. Severe damage and personal injury could result.

Battery Replacement

Make sure that the transceiver power is turned OFF by depressing the Power Switch push-button so that no green LED's are illuminated.

Remove the battery cover door of the transceiver, exposing the battery compartment. Slide the battery holder out of the compartment. Remove the old batteries and replace with fresh, AA (LR6) size alkaline batteries only, taking care to observe the battery polarity markings that are molded into the battery holder. Replace the battery holder and battery door cover of the transceiver. Properly dispose of batteries according to local regulations

WARNING: Remove batteries during prolonged storage. Do not install backwards, charge, put in fire, or mix with other battery types. May explode or leak causing injury. Replace all batteries at the same time.

Accessories & Parts

The use of ACCESSORIES, transducers and cables other than those specified, with the exception of transducers and cables sold by the MANUFACTURER of the ME EQUIPMENT or ME SYSTEM as replacement parts for internal components, may result in increased

EMISSIONS or decreased IMMUNITY of the ME EQUIPMENT or ME SYSTEM.

Item	Catalog Number
Power Supply	108110-SUPPLY
Power Cord	108110-US
Power Cord	108110-EUROPE
Power Cord	108110-JAPAN
Batteries	101325
Instructions for Use	201082

Transducers for use with 108400-AC and 108400		
Item	Catalog Number	Type
20 MHz Curved, Single Use Transducer	102802	CF
20 MHz Single Use, Transducer	108200	CF
20 MHz Single Use Transducer	108380	CF
20 MHz Bayonet, Single Use Transducer	108610	CF
20 MHz Bayonet, Slim, Single Use Transducer	108660	CF
20 MHz Bayonet, Mini, Slim, Single Use Transducer	108665	CF

Transducers for use with 108910-AC and 108910		
Item	Catalog Number	Type

8 MHz Single Use Transducer	108260	CF
8 MHz Single Use Transducer	108370	CF

Limited Warranty

The VTI Doppler Transceiver is warranted for one year from the date of shipment from the factory against defects in materials and workmanship. Defective VTI Doppler Transceivers will be repaired or replaced, at VTI's option, when returned prepaid to the factory within this year.

The customer assumes full responsibility that this equipment meets the specifications, capabilities and other requirements of the customer. VTI makes no warranty of fitness for a particular purpose except as provided herein.

The customer assumes full responsibility for the proper installation, operation and maintenance of this equipment as described in this manual as well as other instructions that may be provided by VTI. This warranty is void if the equipment has been mishandled, operated outside of its specified operating or environmental limits or otherwise subjected to improper or abnormal use.



Obelis s.a.

Bd. General Wahis 53
1030 Brussels, BELGIUM

Tel: + (32) 2. 732.59.54

Fax: + (32) 2. 732.60.03

Email: mail@obelis.net



Manufactured by:



12 Murphy Drive
Nashua, NH 03062
Toll Free 800.550.0856
Outside USA 603.594.9700
Fax 603.594.0092
www.vti-online.com
E-mail info@vti-online.com

© 2015, all rights reserved 201082 R0

